

1

2

3

REVISION HISTORY

REV	DESCRIPTION	DATE	APPROVED
1	First Issue	7/12/10	LH
2	Insulation thickness updated	13/2/12	AH
3	Detail added	16/4/12	AH
4	Detail at Flange altered	18/4/12	AH
5	Notes updated	14/6/12	AH
6	Installation updated	3/6/13	AH

A

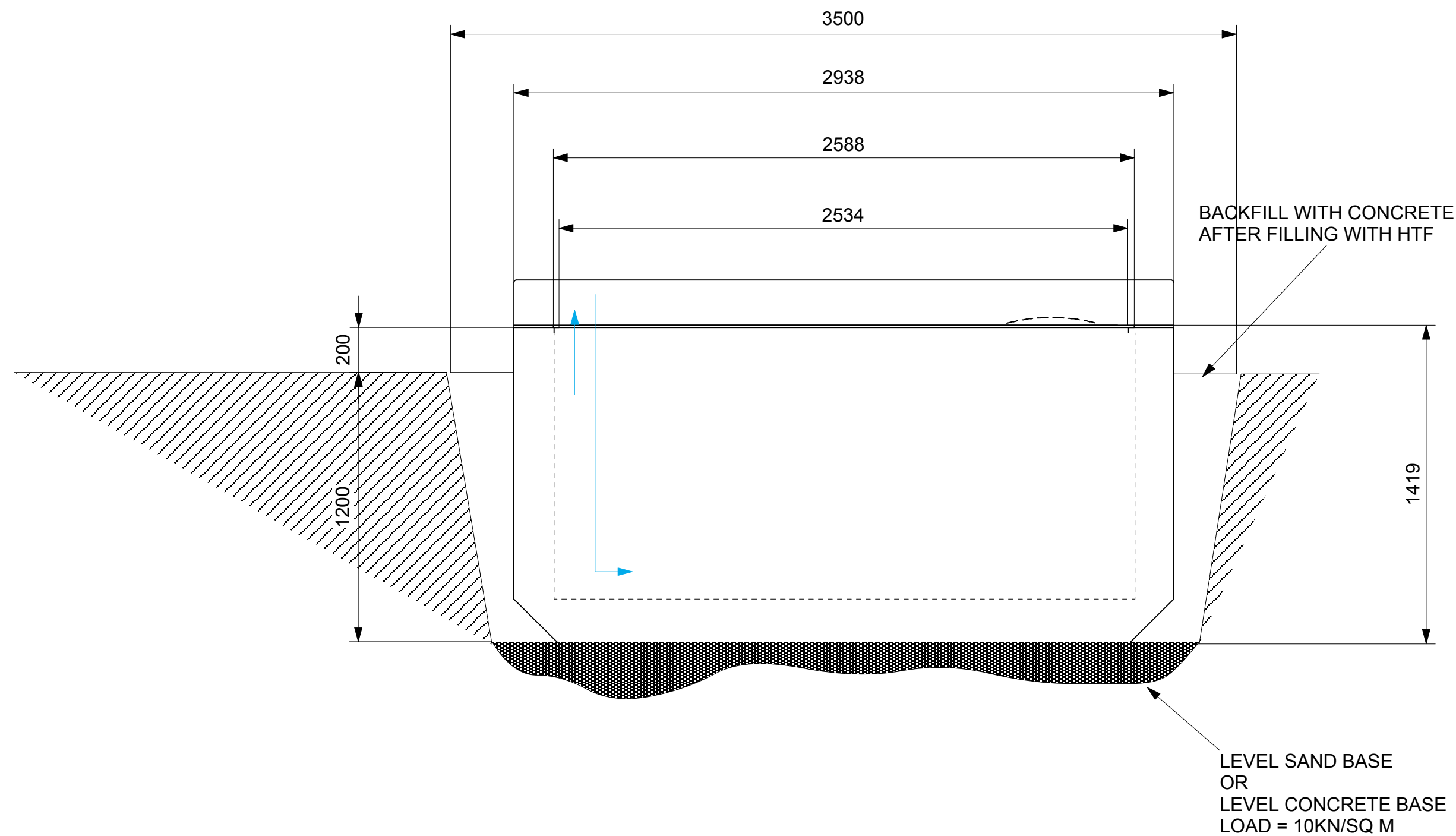

A

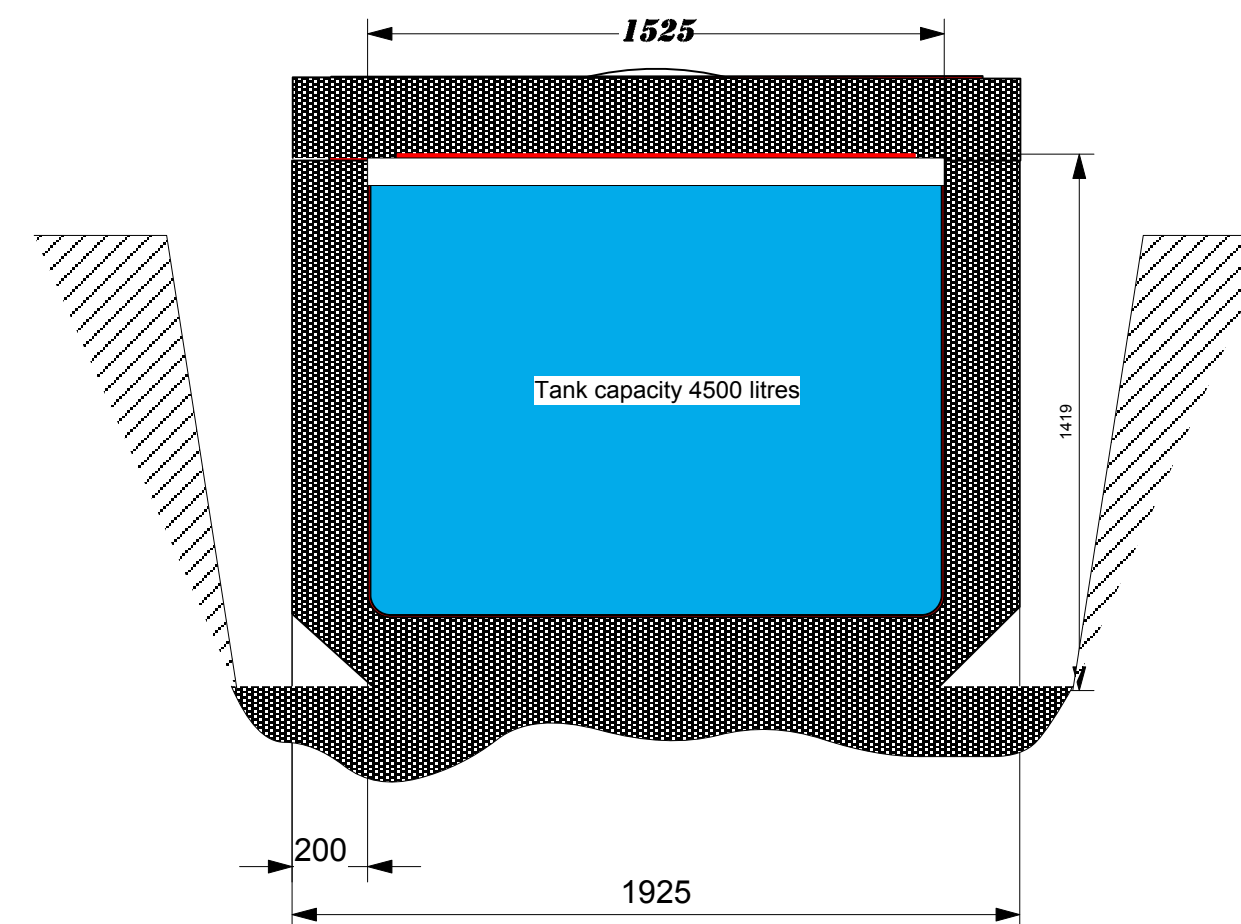

Note:
Tank is to be supplied without Pipework Connections in the ends, and arranged to have the flanges bonded using Polyurethane adhesive sealant.
Insulation 200mm urethane foam Celotex or equal with R value of 9 sqmK/w
After lid is bonded to base, Exposed GRP flange is to be Covered with 100 thick urethane foam, trimmed and painted with Plasticote or equal
Tank skins minimum of 5mm thick GRP laminate with gel coat interior
Floating thermal barrier supplied, pool cover type.

B

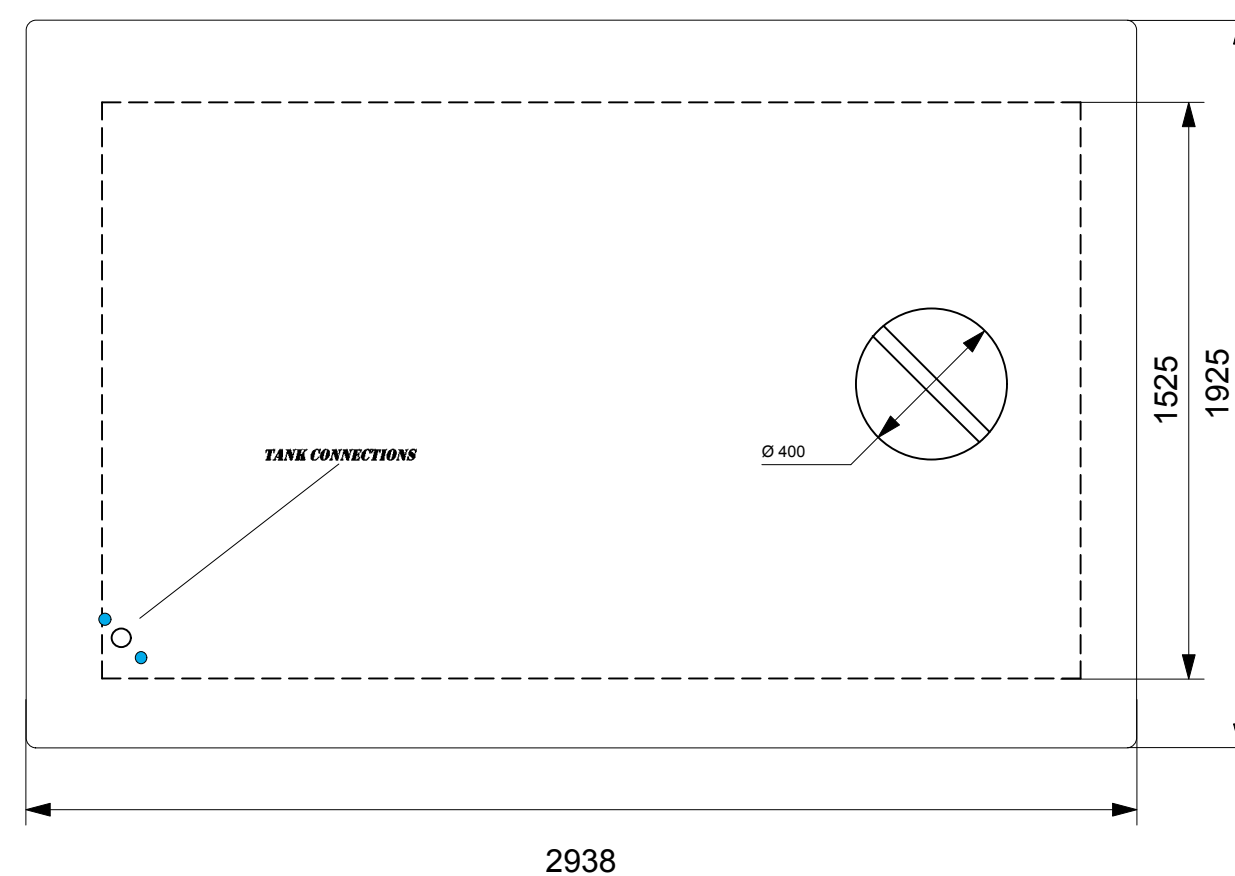

B

TOLERANCES

1 Place: ±.1	3 Places: ±.001
2 Places: ±.01	4 Places: ±.0005
Angular: ±.25°	

THIRD ANGLE PROJECTION

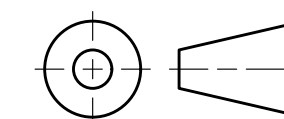

Minus7
Units 1&2 Ivy House Farm,
Wolverhampton Road,
Cheslyn Hay
Staffordshire
WS6 7HX

TITLE Minus7 Hot Store Type HS 45		
DRAWING NUMBER	DRAWN BY	DATE
SCALE 1:10	LH	07/12/10
FILE NAME Minus7 Hot Store HS45		

1

2

3